



Product

DHT HAMMER | 12"

Product Specification

DTH HAMMER	Standard Backhead Size	Outside Diameter (mm/inch)	Length (mm/inch)
12" HAMMER	API 6 5/8 Reg. PIN, BOX	272mm	1789mm
Outside Diameter of Piston (mm/inch)	Stroke (mm/inch)	Weight (kg/lbs)	Shank Type
216mm	100mm	650kg	IR112, SD12, N120

Air Consumption Chart

DTH HAMMER	100 PSI (7kg/cm2)	150 PSI (10.5kg/cm2)	200 PSI (14kg/cm2)
12" HAMMER		880 CFM	1250 CFM
250 PSI (17.5kg/cm2)	300 PSI (21kg/cm2)	350 PSI (25kg/cm2)	
1700 CFM			

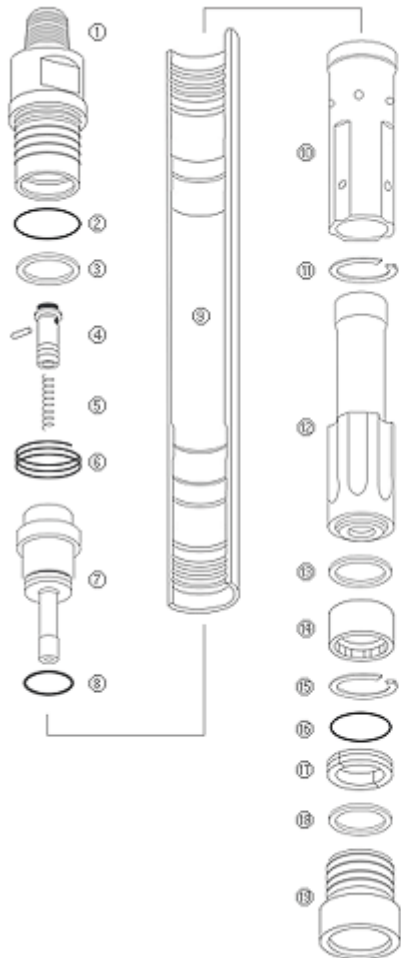

NO	Part Name	Part NO
1	BACK HEAD	1201
2	BACK HEAD "O" RING	1202
3	WASHER SPACER I	1203
4	CHECK VALVE	1204
5	CHECK VALVE SPRING	1205
6	COIL SPRING	1206
7	AIR DISTRIBUTOR	1207
8	A/D "O" RING	1208
9	WEAR SLEEVE	1209
10	CYLINDER	1210
11	CYLINDER RET. RING	1211
12	PISTON	1212
13	PISTON RET RING (URETHANE)	1213
14	BEARING	1214
15	SPRING KEY	1215
16	BIT RET "O" RING	1216
17	BIT RETAINER RING	1217
18	WASHER SPACER II	1218
19	CHUCK	1219